

### Overview

#### HPE Smart Array P222 Controller

The HPE Smart Array P222 Controller is a low profile, 6 Gb/s, PCIe 3.0, Serial Attached SCSI (SAS) RAID controller that provides entry-level, second generation storage performance, scalability, and data protection for select HPE ProLiant Gen8 rack servers and tower servers.

It features four internal and four external SAS ports and delivers increased server uptime by providing advanced storage functionality, including online RAID level migration with flash back write cache, global online spare, and pre-failure warning. Data compatibility between HPE Smart Array Controllers means customers can easily upgrade to future Smart Array Controllers.

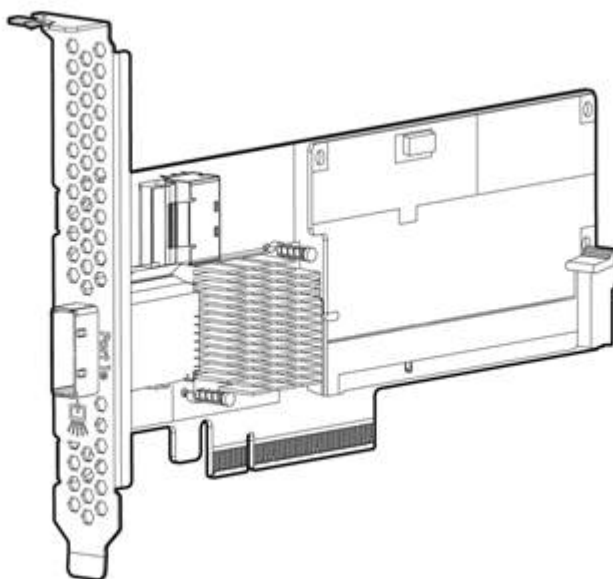

---

#### What's New

- HPE Smart Array Advanced Pack 2.0 features are now part of the base features for the HPE Smart Array P222 Controller at no additional cost.

---

#### Models

<b>HPE Smart Array P222 Controller</b>	HPE Smart Array P222/512 FBWC 6Gb 1-port Int/1-port Ext SAS Controller	631667-B21
--	--	------------

### Standard Features

#### The Smart Array Advantage

HPE's innovative design and integration work of the Smart Array family of products creates customer value that is unmatched in the industry. Use of Smart Array products across multiple applications results in a much lower Total Cost of Ownership (TCO) than any other server storage RAID product. The HPE Smart Array family brings an unparalleled return on investment through:

**Data Compatibility** among most current shipping Smart Array controllers allows simple and easy upgrades any time needs for higher performance, capacity, and availability increase. Even successive generations of Smart Array controllers understand the data format of other Smart Array Controllers.

**Consistent Configuration and Management Tools.** Most current shipping Smart Array products utilize a standard set of management and utility software. These tools minimize Total Cost of Ownership (TCO) by reducing training requirements and technical expertise necessary to install and maintain the HPE server storage.

**SmartDrive Carrier** is for use across multiple Hewlett Packard Enterprise servers, Universal Hard Drive form factor is for disk enclosures and storage systems. With compatibility across many enterprise platforms, you are free to deploy and re-deploy these drives to quickly deliver increased storage capacity, migrate data between systems, and easily manage spare drives.

**Pre-Failure Warranty** means HPE Insight Manager not only reports when a drive is going to fail but allows replacement of failing drives prior to actual failure. For complete details, consult the HPE Support Center or refer to your HPE Server documentation.

---

#### Key Features

- Seamless upgrades from past generations to next generation HPE high performance and high capacity Serial Attached SCSI Smart Array controllers.
- The SA-P222 Controller supports the HPE D2600 Disk Enclosure and HPE D2700 Disk Enclosure.
- 6 Gb/s SAS technology delivers high performance and data bandwidth and contains full compatibility with 3Gb/s SATA technology.
- x8 PCIe 3.0 host interface technology delivers high performance and data bandwidth up to 7.45GB/s maximum bandwidth.
- Addition of the flash backed cache upgrade enables array expansion, logical drive extension, RAID migration, and stripe size migration.
- Standard on the P222 are RAID 6 ADG, RAID 60 ADG, RAID 1 ADM, Capacity Expansion, mirror split, recombine, and rollback in Online Mode, Drive Erase, Performance Optimization-Degraded Reads and Read Coalescing, Move/Delete any individual LUNS and Online Split Mirror.
- The HPE SSD Smart Path feature included in the Smart Array software stack improves SSD read for all RAID levels and RAID 0 write operations by optimizing the path to each SSD attached to the controller.
- Mix-and-match SAS and SATA hard drives, lets you deploy drive technology as needed to fit your computing environment.
- Support for > 2 TB in a single logical drive.
- Support for HPE SAS tape and tape automation products.
- Software consistency on most current shipping Smart Array products: HPE Smart Storage Administrator (HPE SSA), HPE Systems Insight Manager, and Intelligent Provisioning.
- The SA-P222 controller supports up to 54 drives.
- Low-profile PCI Express form factor - ships with a full size bracket for deployment in either a low-profile or full sized slot

### Standard Features

---

#### Online Management Features

- Online Capacity Expansion (with FBWC)
- Advanced Capacity Expansion (with FBWC)
- Online RAID Level Migration (with FBWC)
- Online Stripe Size Migration (with FBWC)
- Online Mirror split, recombine, and rollback
- Unlimited Global Online Spares Assignment
- User Selectable Expand and Rebuild Priority
- User Selectable RAID Level and Stripe Size
- User Selectable Read and Write Cache Sizes
- Supports Predictive Spare Activation

- 
- #### Ports
- Eight (8) SAS physical links distributed across 1 internal x4/1 external x4 wide port connectors.

---

#### Performance

HPE's High Performance Architecture sets new boundaries of industry performance expectations!

- 6Gb/s SAS
- x8 6Gb/s SAS physical links (compatible with 3G SATA)
- 512 MB DDR3-800 MHz 40bit Flash-Backed Write Cache provides up to 4.2 GB/s maximum bandwidth.
- x8 8.5G PCI Express host interface provides 4 GB/s maximum bandwidth.
- MIPS 32-bit Processor
- Read ahead caching
- Flash Backed Write-back Cache

---

#### Native Command Queuing

Native Command Queuing (NCQ) is a technology designed to increase performance of SATA hard disk drives by allowing the individual hard disk to internally optimize the order in which received read and write commands are executed. This can reduce the amount of unnecessary going back-and-forth on the drive's heads, resulting in increased performance for workloads where multiple simultaneous read/write requests are outstanding, most often occurring in server or storage-type applications. Without NCQ the drive has to process and complete one command at a time. For NCQ to be enabled, it must be supported and turned on in the controller and in the hard drive itself.

---

#### Capacity

Given the increasing need for high performance and rapid capacity expansion, the SA-P222 offers:

- Up to 12TB of internal storage with 4x internal 3TB 3.5" SAS/SATA LFF hard drives and up to 144TB of external storage with 4x HPE D2600 Disk Enclosures and 48 x 3TB 3.5" SAS/SATA LFF hard drives.
- Up to 3.6TB of total storage per controller with 4x internal 900GB SFF SAS hard drives and 90TB of external storage with 4x HPE D2700 Disk Enclosures and 100 x 900GB SFF SAS hard drives.
- Up to 4TB of total storage per controller with 4x internal 1TB SFF SATA hard drives and 100TB of external storage with 4x HPE D2700 Disk Enclosures and 100 x 1TB SFF SATA hard drives.

### Standard Features

#### Availability

Provides increased server uptime by providing advanced storage functionality:

- Online Capacity Expansion (with FBWC)
  - Online Advanced Capacity Expansion (with Smart Array Advanced Pack 2.0 upgrade)
  - Online RAID Level Migration (with FBWC )
  - Online Stripe Size Migration (with FBWC)
  - Global Online Spare
  - Pre-Failure Warranty
- 

#### Fault Prevention

The following features offer detection of possible failures before they occur, allowing preventive action to be taken:

- S.M.A.R.T.: Self Monitoring Analysis and Reporting Technology first developed at HPE detects possible hard disk failure before it occurs, allowing replacement of the component before failure occurs.
  - Drive Parameter Tracking monitors drive operational parameters, predicting failure and notifying the administrator.
  - Dynamic Sector Repairing continually performs background surface scans on the hard disk drives during inactive periods and automatically remaps bad sectors, ensuring data integrity.
  - Smart Array Cache Tracking monitors integrity of controller cache, allowing pre-failure preventative maintenance.
- 

#### Fault Tolerance

Keeps data available and server running while a failed drive is being replaced; several fault tolerance configurations are supported including:

- **RAID 6** (Advanced Data Guarding): Supported with a minimum of 4 drives. This allocates two sets of parity data across drives. This level of fault tolerance can withstand a double drive failure without downtime or data loss.
  - **RAID 60**: Supported with a minimum of 8 drives. This volume is composed of two or more RAID 6 sub-volumes (parity groups) where data is striped across each parity group as if it were a single physical drive. Each RAID 6 parity group can sustain up to two drive failures without incurring data loss.
  - **RAID 5** (Distributed Data Guarding): Supported with a minimum of 3 drives. This allocates one set of parity data across drives. This level of fault tolerance can withstand a single drive failure without downtime or data loss.
  - **RAID 50**: Supported with a minimum of 6 drives. This volume is composed of two or more RAID 5 sub-volumes (parity groups) where data is striped across each parity group as if it were a single physical drive. Each RAID 5 parity group can sustain a single drive failure without incurring data loss.
  - **RAID 1 & 10** (Drive Mirroring): Supported with a minimum of 2 drives. This allocates half of the drive array to the data and the other half to the mirrored data, providing two copies of the data.
  - **RAID 1 ADM & 10 ADM** (Advanced Data Mirroring): Supported with a minimum of 3 drives. RAID 1 ADM creates redundant copies of the data using 3 drives. RAID 10 ADM stripes data across two or more sets of RAID 1 ADM volumes. This level of fault tolerance can withstand a double drive failure within a RAID 1 ADM volume without downtime or data loss.
-

### Standard Features

#### Fault Recovery

Minimizes downtime, reconstructs data, and facilitates a quick recovery from drive failure

- On-Line Spares: There is no limit to the number of spare drives that can be installed prior to drive failure. If a failure occurs, recovery begins with an On-Line Spare and data is reconstructed automatically.
- DRAM ECC corrects against single bit data and address corruption.
- Flash Backed Write Cache upgrade provides indefinite data retention

#### Ease of Use

Consistency and upgradeability on most current shipping Smart Array products make them unique in the industry:

- GUI based configuration, management and diagnostic software tools with the HPE Smart Storage Administrator
- Common data format between generations of products
- Data migration between servers and external Modular Smart Array enclosures and HPE Disk Enclosures

**HPE SSD SmartPath** The HPE SSD Smart Path feature included in the Smart Array software stack improves Solid State Disk (SSD) read performance. The Smart Array driver chooses the optimum path to access each SSD. With up to 4x better SSD read performance, HPE SSD Smart path chooses the optimum path to the SSD and accelerates reads for all RAID levels and RAID 0 writes. HPE SSD Smart Path Requires updated firmware, drivers, and configurable utility available here: <http://www.hp.com/go/HPSSDSmartPath>. HPE SSD Smart Path is ideal for read intensive workloads and is included as a base feature on HPE Smart Array P-series controllers. The following operating systems are supported by the HPE SSD Smart Path feature

- Microsoft Windows Server 2008
- Microsoft Windows Server 2008 R2
- Microsoft Windows Server 2012

#### Warranty

The warranty for this device is 3 years parts only.

**Pre-Failure Warranty:** Drives attached to the Smart Array Controller and monitored under Insight Manager are supported by a Pre-Failure (replacement) Warranty. For complete details, consult the HPE Support Center or refer to your HPE Server Documentation.

#### Warranty Upgrade Options

- Response - Upgrade on-site response from next business day to same day 4 hours
- Coverage - Extend hours of coverage from 9 hours x 5 days to 24 hours x 7 days
- Duration - Select duration of coverage for a period of 1, 3, or 5 years
- Warranty upgrade options can come in the form of Care Packs, which are sold at the HPE System level this product attaches too

### Compatibility

**Server Compatibility** For up to date compatibility, please see the following URL for complete Smart Array P222 Controller compatibility and support information:  
<http://h18006.www1.hp.com/products/servers/proliantstorage/arraycontrollers/index.html>

---

**Operating Systems** Microsoft Windows Server  
Microsoft Windows Server Hyper-V  
Red Hat Enterprise Linux (RHEL)  
SUSE Linux Enterprise Server (SLES)  
VMware

**NOTE:** For more information on HPE's Certified and Supported ProLiant Servers for OS and Virtualization Software and the latest listing of software drivers available for your server and Smart Array RAID controller, please visit our Support Matrix at: <http://www.hp.com/go/ossupport>

**NOTE:** For more Linux OS support and certification information, please visit: <http://h18004.www1.hp.com/products/servers/linux/>

---

**Software Suite** Most current shipping Smart Array products share a common set of configuration, management and diagnostic tools, including HPE Smart Storage Administrator, and HPE Systems Insight Manager. This software consistency of tools reduces the cost of training for each successive generation of product and takes much of the guesswork out of troubleshooting field problems. These tools lower the total cost of ownership by reducing training and technical expertise necessary to install and maintain HPE server storage.

**HPE Systems Insight Manager**

- Powerful server and server options/storage manager tool
- Monitors over 1200 system wide parameters
- Configuration/Diagnostic Utilities

**HPE Smart Storage Administrator (HPE SSA)**

- Comprehensive management for HPE Smart Storage products
- Simplified and intuitive interface and functionality
- Advanced scripting and diagnostic features
- For more information please visit: <http://www.hp.com/go/hpsa>

### Service and Support

#### Service and Support HPE Technology Services

Capitalizing on HPE ProLiant server and HPE BladeSystem capabilities requires a service partner who understands your increasingly complex business technology environment. That's why it makes sense to team up with the people who know Hewlett Packard Enterprise infrastructure hardware and software best - the experienced professionals at HPE Services.

#### **Protect your business beyond warranty with HPE Pointnext operational services**

When you buy HPE Options, it's also a good time to think about what level of service you may need. HPE Pointnext operational services provide total care and support expertise with committed response choices designed to meet your IT and business need.

HPE Foundation Care services offer scalable reactive support-packages for Hewlett Packard Enterprise servers and software. You can choose the type and level of service that is most suitable for your IT and business needs. HPE Proactive Care delivers high levels of system availability through proactive service management and advanced technical response.

---

### Recommended HPE Pointnext operational services for your HPE product

#### Optimized Care

#### **3-Year HPE 6 hour Call to Repair Response, Proactive Care**

Combined reactive and proactive support for hardware and software helping optimize your systems and delivering high levels of availability through proactive service management and advanced technical response. Hardware problem resolution to return the hardware in operating condition within 6 hours of the initial service request. A Technical Account Manager, as your single point of contact, will own your call or issue end to end until resolved.

<https://www.hpe.com/h20195/v2/GetPDF.aspx/4AA3-8855EEE.pdf>

#### **HPE Installation of ProLiant Add On Options Service**

This easy-to-buy, easy-to-use HPE Care Pack service helps ensure that your new Hewlett Packard Enterprise hardware or software is installed smoothly, efficiently, and with minimal disruption of your IT and business operations.

---

#### Standard Care

#### **3-Year HPE 24x7 4 hour response, Proactive Care Service**

This service gives you combined reactive and proactive support including rapid access to our Advanced Solution Center to manage and prevent problems and a Technical Support Specialist with a broad level of technical knowledge that will engage with additional technical expertise as needed from HPE's vast global resources.

#### **HPE Installation of ProLiant Add On Options Service**

This easy-to-buy, easy-to-use HPE Care Pack service helps ensure that your new Hewlett Packard Enterprise hardware or software is installed smoothly, efficiently, and with minimal disruption of your IT and business operations.

---

#### Related Services

#### **3 HPE Proactive Care Personalized Support - Environmental Option**

The Personalized Support option provides an assigned Account Support Manager who can bring best practices from across the industry plus extra technical skills to your IT team. This option is only available as an add-on to HPE Proactive Care

### Service and Support

Support

#### **HPE Proactive Select Service**

Provides a flexible way to purchase HPE best-in-class consultancy and technical services. You can buy Proactive Select Service Credits when you purchase your hardware and then use the credits over the next 12 months.

<https://www.hpe.com/h20195/V2/GetPDF.aspx/4AA2-3842ENN.pdf>

**NOTE:** Additional HPE Pointnext operational services can be found at:

<http://hp.com/go/cpc>

---

#### **Insight Online/Insight Remote Support**

HPE Insight Remote Support provides 24 X 7 remote monitoring, proactive notifications, and problem resolution. This comes at no additional cost with your HPE solution. Learn more about Insight Remote Support

<http://www.hp.com/go/insightremotesupport> and Insight Online

<http://h18013.www1.hp.com/products/servers/management/insight-online/index.html>.

---

**HPE Support Center** Personalized online support portal with access to information, tools and experts to support Hewlett Packard Enterprise business products. Submit support cases online, chat with HPE experts, access support resources or collaborate with peers. Learn more <http://www.hp.com/go/hpsc>

The HPE Support Center Mobile App\* allows you to resolve issues yourself or quickly connect to an agent for live support. Now, you can get access to personalized IT support anywhere, anytime.

HPE Insight Remote Support and HPE Support Center are available at no additional cost with a HPE warranty, HPE Care Pack or Hewlett Packard Enterprise contractual support agreement.

**NOTE:** \*The HPE Support Center Mobile App is subject to local availability

---

**Parts and materials** Hewlett Packard Enterprise will provide HPE-supported replacement parts and materials necessary to maintain the covered hardware product in operating condition, including parts and materials for available and recommended engineering improvements.

Parts and components that have reached their maximum supported lifetime and/or the maximum usage limitations as set forth in the manufacturer's operating manual, product QuickSpecs, or the technical product data sheet will not be provided, repaired, or replaced as part of these services.

The defective media retention service feature option applies only to Disk or eligible SSD/Flash Drives replaced by HPE due to malfunction.

---

#### **For more information**

To learn more on services for HPE ProLiant Servers, please contact your Hewlett Packard Enterprise sales representative or Hewlett Packard Enterprise Authorized Channel Partner. Or visit: <http://www.hp.com/services/proliant>

---



### Related Options

**NOTE:** This is a list of supported options. Some may be discontinued.

<b>HPE Hard Drives</b>	<p><b>SAS Hot Plug with SmartDrive SFF (2.5-inch) Enterprise Drives</b></p> <p>HP 146GB 6G SAS 15K rpm SFF (2.5-inch) SC Enterprise 3yr Warranty Hard Drive 652605-B21</p> <p><b>HPE SATA Hard Drives for Gen8 Servers only</b></p> <p><b>6G SATA Hot Plug with SmartDrive SFF (2.5-inch) Midline (MDL) Drives</b></p> <p>HPE 1TB SATA 6G Midline 7.2K SFF (2.5in) SC 1yr Wty Digitally Signed Firmware HDD 655710-B21</p> <p><b>6G SATA Hot Plug with SmartDrive LFF (3.5-inch) Midline (MDL) Drives</b></p> <p>HP 3TB 6G SATA 7.2K rpm LFF (3.5-inch) SC Midline 1yr Warranty Hard Drive 628061-B21</p> <p>HPE 500GB SATA 6G Midline 7.2k LFF (3.5in) SC 1yr Wty HDD 658071-B21</p> <p><b>NOTE:</b> Please visit: <a href="#">HPE Hard Disk Drives QuickSpecs</a> for additional information.</p>
------------------------	---

<b>HPE Tape Drives</b>	<p><b>Tape Libraries</b></p> <p>HPE StorageWorks MSL8096 2 LTO-4 Ultrium 1760 SAS Drive Library AH382A</p> <p>HP StorageWorks MSL8096 2 Ultrium 920 SAS Tape Library AH561A</p> <p><b>SAS Cables for Tape Drives and Automation</b></p> <p>HPE Mini-SAS Cable for LTO Internal Tape Drive AP746A</p> <p><b>NOTE:</b> Use this cable to connect HPE Ultrium 448, 920, 960, 1760 and 1840 SAS internal tape drives to Mini-SAS (SFF8087) ports. This replaces the existing cable connecting the HBA/controller to the disk backplane. This replacement cable has three channels for disks and 1 channel for the tape drive (SFF8482 port).</p> <p>HPE SAS Min-Min 1x-2M Cable Assembly Kit AE470A</p> <p><b>NOTE:</b> Use this cable to connect HPE SAS external tape devices to HPE SAS controllers with external Mini-SAS (SFF8088) connectors.</p> <p>HPE SAS MIN-MIN 1X-4M Cable Assembly Kit AE465A</p> <p><b>NOTE:</b> Use this cable to connect HPE SAS external tape devices to HPE SAS controllers with external Mini-SAS (SFF8088) connectors.</p> <p>HPE SAS MIN-MIN 3X1X-5M Cable Assembly Kit AG452A</p> <p><b>NOTE:</b> This split cable connects internally to SAS Hard Drive Cage (3 channels) and externally to the tape drive (1channel) with other connector attaching to the controller. The external cable, for the drive, requires a PCI slot to exit the server.</p> <p>HPE StoreEver 2m External Mini-SAS to 4x1 Mini-SAS Cable AN975A</p> <p><b>NOTE:</b> One cable is required for every four drives. Use this cable to connect HPE MSL SAS Tape Libraries to Mini-SAS (SFF8088) ports.</p> <p>HPE StoreEver 4m External Mini-SAS to 4x1 Mini-SAS Cable AN976A</p> <p><b>NOTE:</b> One cable is required for every four drives. Use this cable to connect HPE MSL SAS Tape Libraries to Mini-SAS (SFF8088) ports.</p>
------------------------	---

### Related Options

---

#### **HPE Cable Options** Mini SAS Cables

HPE Mini SAS Straight to Straight 37in Cable Assembly

662897-B21

HPE Double Mini SAS Y 36in Cable Assembly

662901-B21

### Technical Specifications

<b>Dimensions</b> (not including bracket)	Low Profile PCIe Form Factor 19.05 cm x 24.13 cm x 5.72cm (7.5 in x 9.5 in x 2.25 in)
<b>Disk Drive and Enclosure Protocol Support - Transfer rate</b>	6Gb/s SAS (Serial Attached SCSI) 6Gb/s SATA (Serial ATA)
<b>SAS Connectors</b>	1 internal (SFF-8087)/1 external (Mini-SAS SFF-8088) x8 wide port connectors
<b>Cache Memory Speed</b>	DDR-3/800 MHz with 40-bit wide bus provides up to 4.2 GB/s maximum bandwidth.
<b>Server Interface</b>	x8 5G PCIe 3.0 provides 4GB/s maximum bandwidth.
<b>SAS Speed</b>	x8 6G SAS provides 4.8GB/s maximum bandwidth.
<b>Cache Memory</b>	40-bit 512MB ECC protected cache
<b>Logical Drives Supported</b>	Up to 64 logical volumes
<b>Maximum Volume Capacity</b>	12TB (4 x 3TB SAS/SATA 3.5" MDL HDD) internal 144TB (48 x 3TB SAS/SATA 3.5" MDL HDD) external with 4xD2600 90TB (100 x 900GB SAS 2.5" HDD) external with 4xD2700
<b>Memory Addressing</b>	64-bit, supporting servers memory space greater than 4 GB
<b>RAID Support</b>	RAID 6, 60 (Advanced Data Guarding) RAID 5, 50 (Distributed Data Guarding) RAID 1, 10 (Drive Mirroring) RAID 1 ADM, 10 ADM (Advanced Data Mirroring) RAID 0 (Striping)
<b>Upgradeable Firmware</b>	Upgradeable Firmware with Recovery ROM feature

### Environment-friendly Products and Approach

### End-of-life Management and Recycling

Hewlett Packard Enterprise offers end-of-life product return, trade-in, and recycling programs, in many geographic areas, for our products. Products returned to Hewlett Packard Enterprise will be recycled, recovered or disposed of in a responsible manner.

<http://www.hpe.com/recycle>

The EU WEEE directive (2002/95/EC) requires manufacturers to provide treatment information for each product type for use by treatment facilities. This information (product disassembly instructions) is posted on the Hewlett Packard Enterprise web site. These instructions may be used by recyclers and other WEEE treatment facilities as well as Hewlett Packard Enterprise OEM customers who integrate and re-sell Hewlett Packard Enterprise equipment.

<http://www.hpe.com/recycle>

### Summary of Changes

Date	Version History	Action	Description of Change
23-Oct-2017	From Version 12 to 13	Changed	Care Pack naming and Service and Support-Parts and Materials updated.
12-Jun-2017	From Version 11 to 12	Changed	Changes were made throughout the QuickSpecs.
17-Jun-2014	From Version 10 to 11	Changed	Changes were made throughout the QuickSpecs.
10-Jun-2013	From Version 9 to 10	Added	Compatibility: Added HPE SSD SmartPath section
		Changed	Overview: Updated What's New with <ul style="list-style-type: none"> <li>Up to 4x better Solid State Disk (SSD) read performance with the SSD Smart Path firmware and driver based feature for Smart Array controllers.</li> </ul> Standard Features: Updated Key Features.
19-Feb-2013	From Version 8 to 9	Changed	Changed Overview, Standard Features and Related Options.
04-Dec-2012	From Version 7 to 8	Added	Added and updated Hard Drivers in Related Options section.
26-Nov-2012	From Version 6 to 7	Added	Added missing sub-header in Related Options section.
06-Jun-2012	From Version 5 to 6	Changed	Smart Drive was changed to SmartDrive in Standard Features.
16-May-2012	From Version 4 to 5	Changed	The Hard Drives section was revised.
06-Apr-2012	From Version 3 to 4	Changed	Changes made in the Standard Features and Technical Specifications sections.
15-Mar-2012	From Version 2 to 3	Changed	Changes made in the Hard Drives section of Related Options.
07-Mar-2012	From Version 1 to 2	Changed	Changes made in the Hard Drives section of Related Options.





  
[Sign up for updates](#)

© Copyright 2017 Hewlett Packard Enterprise Development LP. The information contained herein is subject to change without notice. The only warranties for Hewlett Packard Enterprise products and services are set forth in the express warranty statements accompanying such products and services. Nothing herein should be construed as constituting an additional warranty. Hewlett Packard Enterprise shall not be liable for technical or editorial errors or omissions contained herein.

Microsoft and Windows are registered trademarks or trademarks of Microsoft Corporation in the U.S. and/or other countries.

For hard drives, 1GB = 1 billion bytes. Actual formatted capacity is less.

c04111474 - 14227 - Worldwide - V13 - 23-October-2017

